

## FT1 FLOOR TROUGH

# Commercial Floor Waste with Bucket Trap

**ASD**  
ALL SYSTEM DRAINS

### PRODUCT INFORMATION

- Stainless steel grade 304
- Manufactured to any custom length - 600mm minimum to 2000mm maximum
- Built in fall to bucket trap
- Welded-in bucket trap
- Removable basket
- Anti-slip grate
- Australian made product



FT1 Floor trough with bucket trap

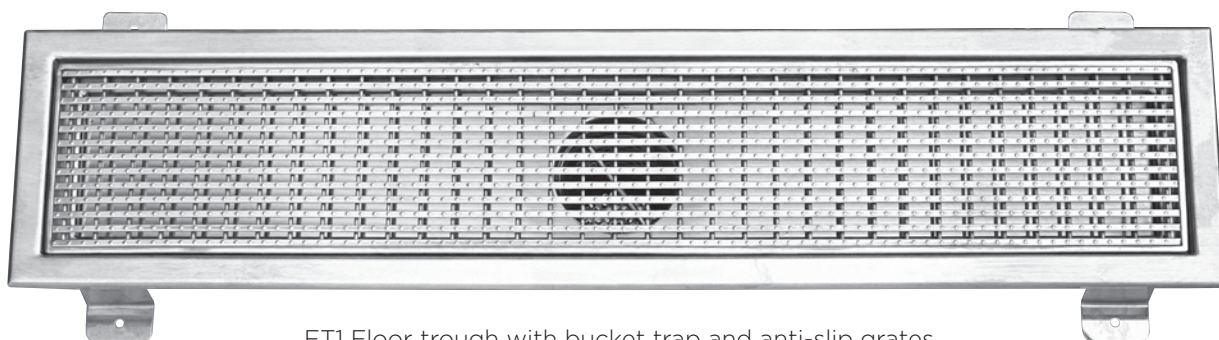

FT1 Floor trough with bucket trap and anti-slip grates



Removable  
stainless steel  
basket

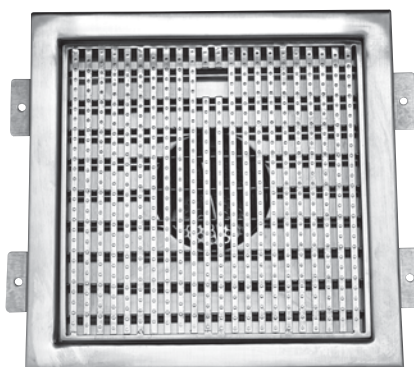

Other custom  
sized floor troughs  
also available  
on request

**W**  
WMK26793  
SAI GLOBAL

# FT1 FLOOR TROUGH

## Commercial Floor Waste with Bucket Trap

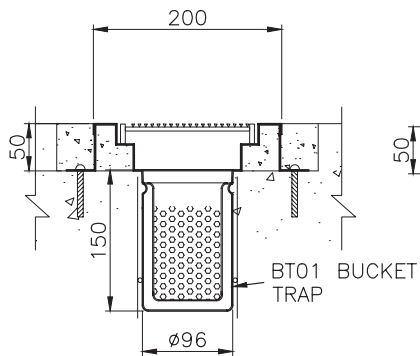

Plan of FT1 bucket trap

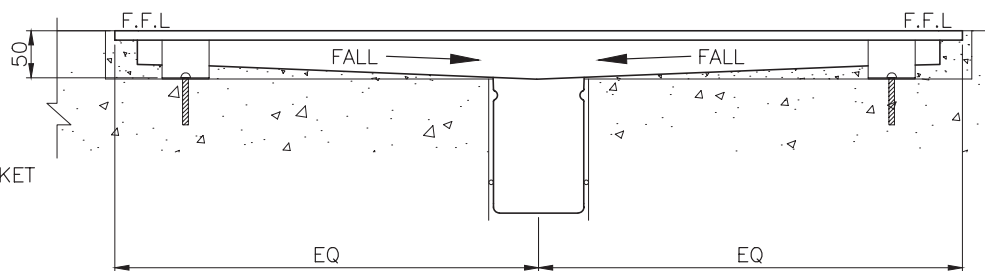

Elevation of typical FT1 floor trough

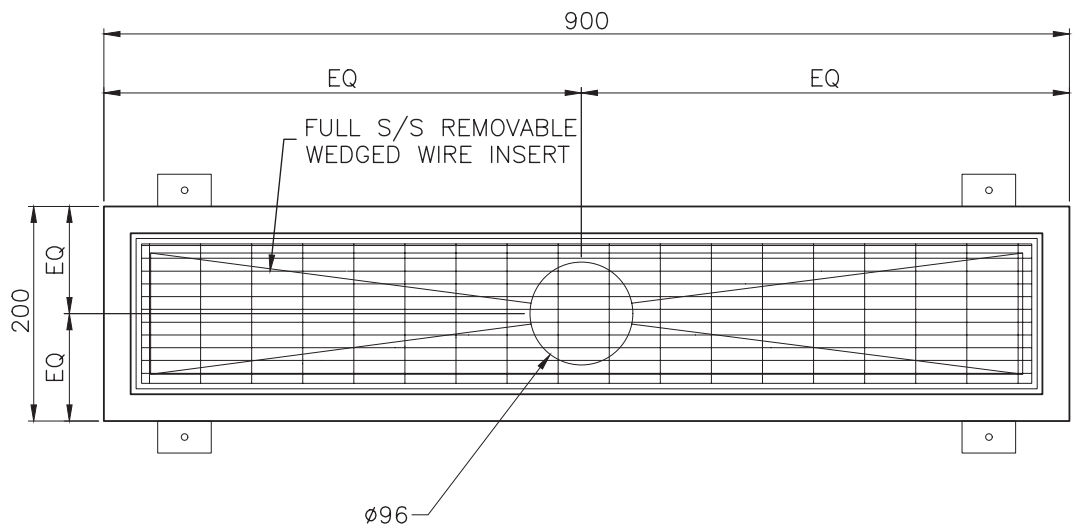

Plan of typical FT1 floor trough

### OPTIONS

- Vinyl clamp for use with vinyl floor coverings
- Manufactured to any custom length - 600mm minimum to 2000mm maximum
- Centred or offset drain outlet location
- Fast turnaround times - most lead times within 10 working days



FT2 FLOOR TROUGH

# Commercial Floor Waste with Bucket Trap



## PRODUCT INFORMATION

- Stainless steel grade 304
- Manufactured to any custom length - 2000mm minimum to 4500mm maximum
- Built in fall to bucket trap
- Welded-in bucket trap
- Removable basket
- Anti-slip grate
- Australian made product



FT2 Floor trough with bucket trap



FT2 Floor trough with bucket trap and anti-slip grates



Removable  
stainless steel  
basket

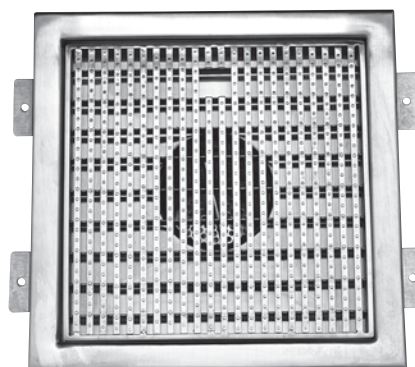

Other custom  
sized floor troughs  
also available  
on request





## FT2 FLOOR TROUGH

# Commercial Floor Waste with Bucket Trap

**ASD**  
ALL SYSTEM DRAINS



Plan of FT2 bucket trap

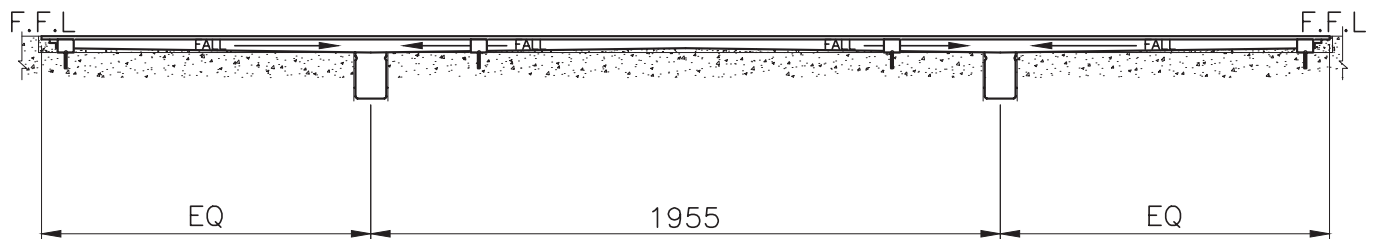
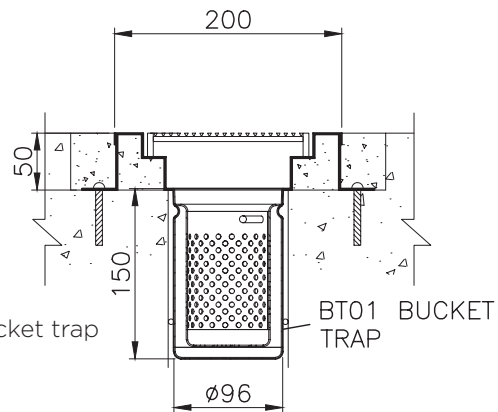

Elevation of typical FT2 floor trough

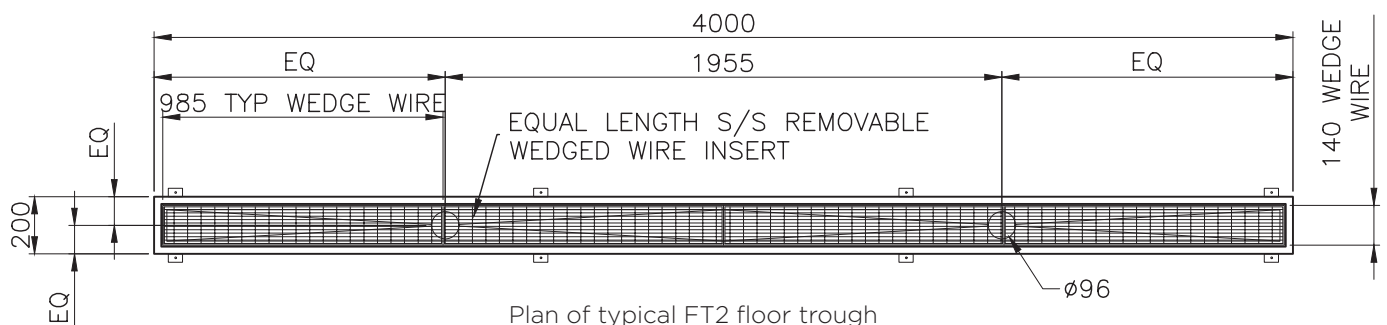

Plan of typical FT2 floor trough

## OPTIONS

- Vinyl clamp for use with vinyl floor coverings
- Manufactured to any custom length - 2000mm minimum to 4500mm maximum
- Centred or offset drain outlet location
- Fast turnaround times - most lead times within 10 working days

**W**  
WMK26793  
SAI GLOBAL